

2/2-WAY SOLENOID VALVE

TYPE 32



O₂ oxygene applications



DESCRIPTION

Valve type 32 is a 2/2-way direct acting solenoid valve for general applications with gases and liquids for low to medium pressure.

CONSTRUCTION

Body material	stainless steel
Internal parts	stainless steel
Sealing material	NBR, EPDM, FPM
Voltages	24 V DC, 24 V 50Hz, 230 V 50Hz
Connections	G1/8

ON REQUEST

Valve for oxygene applications
 Non-standard coil voltages
 Higher ambient temperature range
 Non-standard equipment
 Manual override

SWITCHING PRESSURE

Orifice in mm	Normally closed in bar	Normally open in bar
1,2	30,0	15,0
1,5	30,0	7,0
2,0	30,0	5,0
2,5	16,0	4,0
3,0	11,0	3,0
3,5	-	2,0
4,0	4,0	1,8

See details on the website

VARIANTS

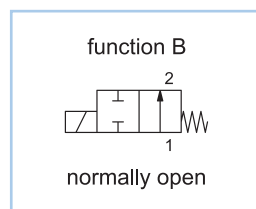
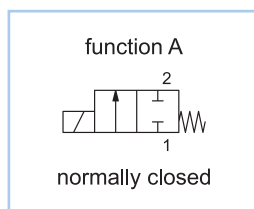

DETAILED INFORMATION

General	
type of construction	2/2-way poppet valve, normally closed NC or normally open NO, coil 360° rotatable
operation	electrically, on request: manual override
ports	G1/8
ambient temperature	-20°C to +50°C, higher acceptable ambient temperature range on request
fluid temperature	dependent on sealing material and coil
viscosity	max. 21 mm ² /s (cst)
material	body and plunger tube: AISI 303 internal parts: stainless steel sealing: see type selection
mounting	installation into fixed piping systems or by use of 2 threads M3
installation	in any position, preferable vertically fixed solenoid coil
unit of supply	without connector

Electrical	
voltage	DC voltage or AC voltage
standard voltages	24 V DC, 24 V 50Hz, 230 V 50Hz
non-standard voltage on request	6 V - 200 V DC, 12 V - 240 V 50Hz or 60Hz
acceptable voltage tolerance	±10%
power consumption	see specifications at solenoid coils
coil temperature classification	temperature class F (155°C), winding class H (180°C)
duty cycle	100%, continuous operation
protection class	IP65 according DIN EN 60529 (DIN 40050) with correctly mounted connector

Pneumatic – Hydraulic	
fluid	all liquids and gases, non-aggressive to the used material
max. valve body pressure	PN 40
response time	12 - 20 ms
non-standard equipment on request	coil type with cable, coils for temperature class H (180°C), higher differential pressure, other sealing materials

2/2-WAY SOLENOID VALVE

TYPE 32



O₂ oxygene applications

CONFIGURATION & PRESSURE RANGE

Coil power consumption at 20°C			
coil type	inrush power 50Hz in VA	rated power 50Hz in VA	power DC in W
C1DA	9	5	3
C2DA	13	10	6,5
C3AA	17	13	6,3

Sealing material	Code	Fluid temperature	Applicable for
NBR (Perbunan)	B	-10°C to 80°C	neutral gases and liquids
EPDM	E	-10°C to 130°C	hot water, steam, not for oil and grease
FPM	V	-10°C to 130°C	oil, petrol, oxygen

NORMALLY CLOSED VALVES

Type 32A, normally closed									
type (order-no.)	NW DN in mm	ports	maximum differential pressure in bar						kv-value in m ³ /h
			coil C1DA		coil C2DA		coil C3AA		
			50Hz	DC	50Hz	DC	50Hz	DC	
32A-1.12-A...	1,2	G1/8	30,0	30,0	30,0	30,0	30,0	30,0	0,045
32A-1.15-A...	1,5	G1/8	25,0	10,0	30,0	30,0	30,0	30,0	0,082
32A-1.20-A...	2,0	G1/8	12,0	1,5	18,0	8,0	30,0	16,0	0,133
32A-1.25-A...	2,5	G1/8	6,0	0,8	10,0	3,0	16,0	7,0	0,195
32A-1.30-A...	3,0	G1/8	4,0	-	6,0	2,0	11,0	3,7	0,250
32A-1.40-A...	4,0	G1/8	1,0	-	2,0	0,5	4,0	1,2	0,340

NORMALLY OPEN VALVES

Type 32B, normally open									
type (order-no.)	NW DN in mm	ports	maximum differential pressure in bar						kv-value in m ³ /h
			coil C1DA		coil C2DA		coil C3AA		
			50Hz	DC	50Hz	DC	50Hz	DC	
32B-1.12BZ-A...	1,2	G1/8	5,5	5,5	-	-	-	-	0,045
32B-1.15BZ-A...	1,5	G1/8	3,0	3,0	-	-	-	-	0,082
32B-1.20BZ-A...	2,0	G1/8	2,5	2,5	-	-	-	-	0,133
32B-1.25BZ-A...	2,5	G1/8	2,0	2,0	-	-	-	-	0,195
32B-1.30DZ-A...	3,0	G1/8	2,5	-	-	-	-	-	0,250
32B-1.35DZ-A...	3,5	G1/8	2,0	-	-	-	-	-	0,295
32B-1.40DZ-A...	4,0	G1/8	1,7	-	-	-	-	-	0,340
32B-1.12FZ-A...	1,2	G1/8	-	-	9,5	9,5	-	-	0,045
32B-1.15FZ-A...	1,5	G1/8	-	-	7,0	7,0	-	-	0,082
32B-1.20FZ-A...	2,0	G1/8	-	-	3,5	3,5	-	-	0,133
32B-1.25FZ-A...	2,5	G1/8	-	-	2,5	2,5	-	-	0,195
32B-1.30FZ-A...	3,0	G1/8	-	-	2,0	2,0	-	-	0,250
32B-1.35FZ-A...	3,5	G1/8	-	-	1,7	1,7	-	-	0,295
32B-1.40FZ-A...	4,0	G1/8	-	-	1,5	1,5	-	-	0,340
32B-1.12GZ-A...	1,2	G1/8	-	-	-	-	15,0	15,0	0,045
32B-1.15GZ-A...	1,5	G1/8	-	-	-	-	7,0	7,0	0,082
32B-1.20GZ-A...	2,0	G1/8	-	-	-	-	5,0	5,0	0,133
32B-1.25GZ-A...	2,5	G1/8	-	-	-	-	4,0	4,0	0,195
32B-1.30GZ-A...	3,0	G1/8	-	-	-	-	3,0	3,0	0,250
32B-1.35GZ-A...	3,5	G1/8	-	-	-	-	2,0	2,0	0,295
32B-1.40GZ-A...	4,0	G1/8	-	-	-	-	1,8	1,8	0,340

2/2-WAY SOLENOID VALVE

TYPE 32



O_2 oxygene applications

ORDER CODE

Type 32A, normally closed												
order code	32	A	-	1	V	30	-	A	C3AA	23050		
Type 32B, normally open												
order code	32	B	-	1	V	30	G	Z	-	A	C3AA	23050
Code decoding												
type	type 32, direct operated, body and plunger tube: stainless steel											
function	A = normally closed, B = normally open											
ports	1 = G1/8											
seal material	B = NBR (Perbunan), E = EPDM, V = FPM											
nominal size seat	12 = 1,2 mm, 15 = 1,5 mm, 20 = 2,0 mm, 25 = 2,5 mm, 30 = 3,0 mm, 35 = 3,5 mm, 40 = 4,0 mm											
throw off spring	C, D, F, G = only normally open											
stroke compensation spring	Z = only normally open											
short circuit ring	A = copper short circuit ring, X = without short circuit ring											
coil type	see specifications of the particular coil											
supply voltage	always 5-digits, see code for standard voltage											

DIMENSIONS

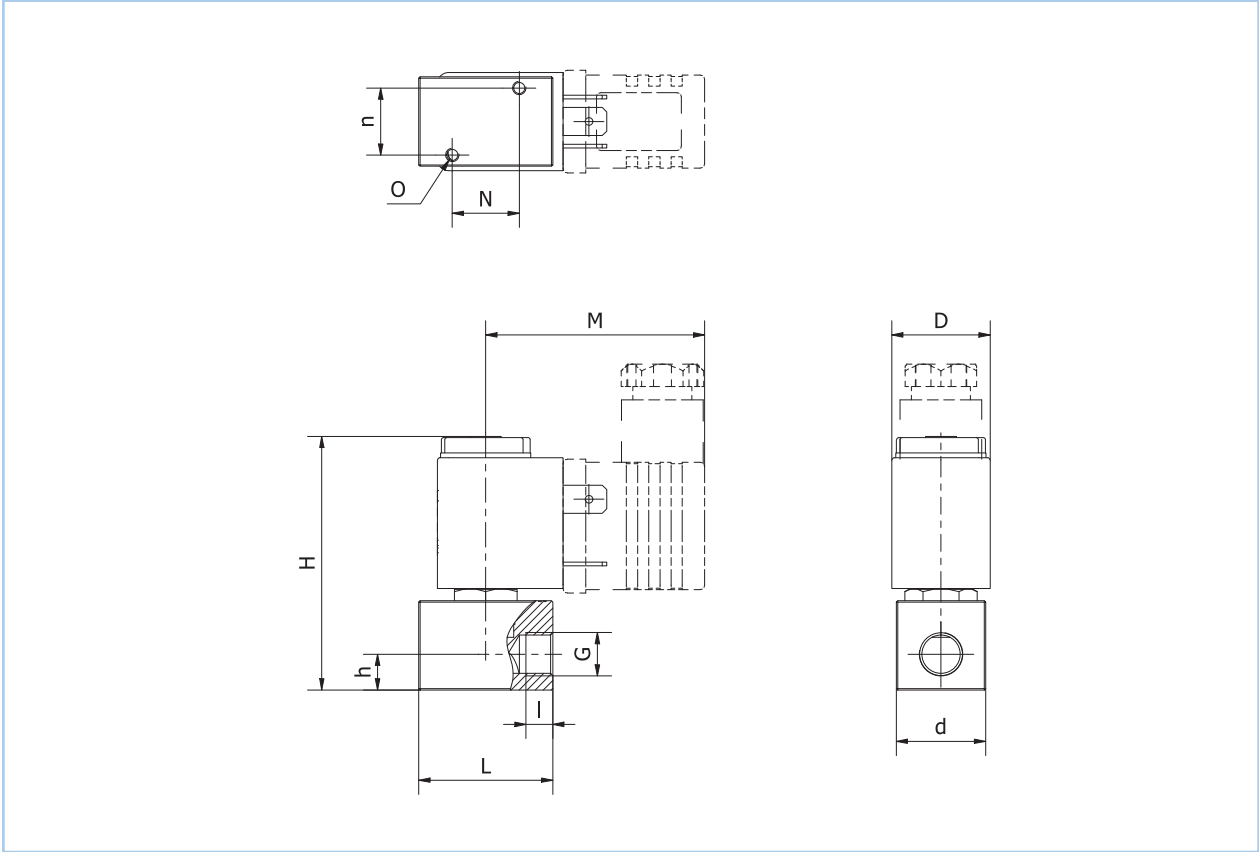

Dimension table for type 32 in mm, approx. weight in g														
coil	G	N	n	O	M	H		h	I	L	D	d	approx. weight in g	
						type 32A	type 32B						type 32A	type 32B
C1DA	G1/8	15	15	M3	49	57	58,5	8	6	30	22	20	142	142
C2DA	G1/8	15	15	M3	49	57	58,5	8	6	30	22	20	142	142
C3AA	G1/8	15	15	M3	53,5	57	58,5	8	6	30	30	20	197	197