

2/2-WAY SOLENOID VALVE

TYPE 20



O_2 oxygene applications



DESCRIPTION

Valve type 20 is a 2/2-way direct acting solenoid valve for general applications with gases and liquids for low to medium pressure.

CONSTRUCTION

Body material	brass
Internal parts	brass and stainless steel
Sealing material	NBR, EPDM, FPM, PTFE, FFPM
Voltages	24 V DC, 24 V 50Hz, 230 V 50Hz
Connections	G1/8 - G1/2

ON REQUEST

Valve for oxygene applications
 Non-standard coil voltages
 Higher ambient temperature range
 Non-standard equipment
 Manual override

SWITCHING PRESSURE

Orifice in mm	Normally closed in bar	Normally open in bar
1,5	40,0	30,0
2,0	40,0	20,0
2,5	40,0	14,0
3,0	40,0	10,5
3,5	31,0	8,0
4,0	20,0	6,0
5,0	18,0	4,0
6,0	12,0	4,0
8,0	2,5	-
10,0	1,7	-

See details on the website

VARIANTS

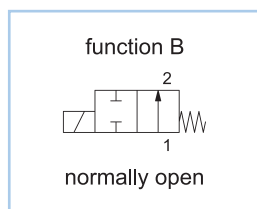
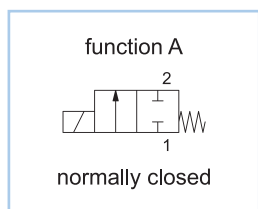

DETAILED INFORMATION

General	
type of construction	2/2-way poppet valve, normally closed NC or normally open NO, coil 360° rotatable
operation	electrically, on request: manual override
ports	G1/8 - G1/2
ambient temperature	-20°C to +50°C, higher acceptable ambient temperature range on request
fluid temperature	dependent on sealing material and coil
viscosity	max. 21 mm ² /s (cst)
material	body: brass plunger tube: AISI 303 internal parts: brass and stainless steel sealing: see type selection
mounting	installation into fixed piping systems or by use of 2 threads on the bottom side
installation	in any position, preferable vertically fixed solenoid coil
unit of supply	without connector

Electrical	
voltage	DC voltage or AC voltage
standard voltages	24 V DC, 24 V 50Hz, 230 V 50Hz
non-standard voltage on request	6 V - 200 V DC, 12 V - 240 V 50Hz or 60Hz
acceptable voltage tolerance	±10%
power consumption	see specifications at solenoid coils
coil temperature classification	temperature class F (155°C), winding & coil E3 temperature class H (180°C)
duty cycle	100%, continuous operation
protection class	IP65 according DIN EN 60529 (DIN 40050) with correctly mounted connector

Pneumatic – Hydraulic	
fluid	all liquids and gases, non-aggressive to the used material
max. valve body pressure	PN 64 up to DN 4 mm, PN 25 from DN 5 – 10 mm
response time	depending on operating pressure and fluid
non-standard equipment on request	stainless steel AISI 303 in place of brass, coil type with cable, bright nickel-plated or chemical nickel-plated, coils for temperature class H (180°C), higher differential pressure, PTFE seal

CONFIGURATION & PRESSURE RANGE

Sealing material	Code	Fluid temperature	Applicable for
NBR (Perbunan)	B	-10°C to 80°C	neutral gases and liquids
EPDM	E	-10°C to 130°C	hot water, steam, not for oil and grease
FPM	V	-10°C to 130°C	oil, petrol, oxygen
PTFE	T	-10°C to 150°C	acids and alkaline solution, steam
FFPM	K	-10°C to 150°C	excellent chemical resistance, wide temperature range

2/2-WAY SOLENOID VALVE

TYPE 20



O_2 oxygene applications

NORMALLY CLOSED VALVES

Type 20A, normally closed									
type (order-no.)	NW DN in mm	ports	maximum differential pressure in bar						
			coil E5AA		coil E4AA		coil E1AA		
			50Hz	DC	50Hz	DC	50Hz	DC	
20A-1.15-A...	1,5	G1/8	-	40,0	-	40,0	40,0	40,0	
20A-2.15-A...	1,5	G1/4	-	40,0	-	40,0	40,0	40,0	
20A-1.20-A...	2,0	G1/8	-	18,0	-	28,0	30,0	35,0	
20A-2.20-A...	2,0	G1/4	-	18,0	-	28,0	30,0	35,0	
20A-1.25-A...	2,5	G1/8	-	11,0	-	12,0	25,0	20,0	
20A-2.25-A...	2,5	G1/4	-	11,0	-	12,0	25,0	20,0	
20A-1.30-A...	3,0	G1/8	-	4,4	-	5,6	12,0	8,0	
20A-2.30-A...	3,0	G1/4	-	4,4	-	5,6	12,0	8,0	
20A-1.35-A...	3,5	G1/8	-	2,6	-	3,6	10,0	5,0	
20A-2.35-A...	3,5	G1/4	-	2,6	-	3,6	10,0	5,0	
20A-1.40-A...	4,0	G1/8	-	2,1	-	2,7	7,2	3,0	
20A-2.40-A...	4,0	G1/4	-	2,1	-	2,7	7,2	3,0	
20A-2.50-A...	5,0	G1/4	-	0,3	-	0,6	3,5	1,0	
20A-3.50-A...	5,0	G3/8	-	0,3	-	0,6	3,5	1,0	
20A-4.50-A...	5,0	G1/2	-	0,3	-	0,6	3,5	1,0	
20A-2.60-A...	6,0	G1/4	-	-	-	0,2	2,7	0,5	
20A-3.60-A...	6,0	G3/8	-	-	-	0,2	2,7	0,5	
20A-4.60-A...	6,0	G1/2	-	-	-	0,2	2,7	0,5	
20A-3.80-A...	8,0	G3/8	-	-	-	-	0,5	-	
20A-4.80-A...	8,0	G1/2	-	-	-	-	0,5	-	
20A-3.100-A...	10,0	G3/8	-	-	-	-	0,4	-	
20A-4.100-A...	10,0	G1/2	-	-	-	-	0,4	-	

CONFIGURATION & PRESSURE RANGE

Coil power consumption at 20°C			
coil type	inrush power 50Hz in VA	rated power 50Hz in VA	power DC in W
E5AA	-	-	8
E4AA	-	-	10
E1AA	32	14	12
E2AA	42	19	17
E3AE	70	32	27
F1AA	70	35	27

	Type 20A, normally closed						
	maximum differential pressure in bar						kv-value in m³/h
	coil E2AA		coil E3AE		coil F1AA		
	50Hz	DC	50Hz	DC	50Hz	DC	
	40,0	40,0	40,0	40,0	-	-	0,08
	40,0	40,0	40,0	40,0	-	-	0,08
	40,0	40,0	40,0	40,0	-	-	0,13
	40,0	40,0	40,0	40,0	-	-	0,13
	40,0	40,0	40,0	40,0	-	-	0,19
	40,0	40,0	40,0	40,0	-	-	0,19
	24,0	40,0	32,0	40,0	-	-	0,25
	24,0	40,0	32,0	40,0	-	-	0,25
	17,0	18,0	26,0	31,0	-	-	0,30
	17,0	18,0	26,0	31,0	-	-	0,30
	12,0	15,0	17,0	20,0	-	-	0,37
	12,0	15,0	17,0	20,0	-	-	0,37
	6,5	4,0	7,5	7,0	18,0	18,0	0,55
	6,5	4,0	7,5	7,0	18,0	18,0	0,55
	6,5	4,0	7,5	7,0	18,0	18,0	0,55
	4,5	2,0	4,5	3,4	12,0	12,0	0,67
	4,5	2,0	4,5	3,4	12,0	12,0	0,67
	4,5	2,0	4,5	3,4	12,0	12,0	0,67
	1,3	0,4	2,0	0,7	2,5	1,20	1,25
	1,3	0,4	2,0	0,7	2,5	1,20	1,25
	1,0	0,1	1,4	0,5	1,7	0,80	1,95
	1,0	0,1	1,4	0,5	1,7	0,80	2,00

2/2-WAY SOLENOID VALVE

TYPE 20



O_2 oxygene applications

NORMALLY OPEN VALVES

Type 20B, normally open									
type (order-no.)	NW DN in mm	ports	maximum differential pressure in bar						
			coil E5AA		coil E4AA		coil E1AA		
			50Hz	DC	50Hz	DC	50Hz	DC	
20B-1.15CZ-A...	1,5	G1/8	-	-	-	-	-	-	-
20B-2.15CZ-A...	1,5	G1/4	-	-	-	-	-	-	-
20B-1.20CZ-A...	2,0	G1/8	-	-	-	-	-	-	-
20B-2.20CZ-A...	2,0	G1/4	-	-	-	-	-	-	-
20B-1.25CZ-A...	2,5	G1/8	-	-	-	-	14,0	-	-
20B-2.25CZ-A...	2,5	G1/4	-	-	-	-	14,0	-	-
20B-1.30CZ-A...	3,0	G1/8	-	-	-	-	10,5	-	-
20B-2.30CZ-A...	3,0	G1/4	-	-	-	-	10,5	-	-
20B-1.35CZ-A...	3,5	G1/8	-	-	-	-	8,0	-	-
20B-2.35CZ-A...	3,5	G1/4	-	-	-	-	8,0	-	-
20B-1.40CZ-A...	4,0	G1/8	-	-	-	-	6,0	-	-
20B-2.40CZ-A...	4,0	G1/4	-	-	-	-	6,0	-	-
20B-2.50CZ-A...	5,0	G1/4	-	-	-	-	-	-	-
20B-3.50CZ-A...	5,0	G3/8	-	-	-	-	-	-	-
20B-4.50CZ-A...	5,0	G1/2	-	-	-	-	-	-	-
20B-2.60CZ-A...	6,0	G1/4	-	-	-	-	-	-	-
20B-3.60CZ-A...	6,0	G3/8	-	-	-	-	-	-	-
20B-4.60CZ-A...	6,0	G1/2	-	-	-	-	-	-	-

Type 20B, normally open							
maximum differential pressure in bar							kv-value in m ³ /h
coil E2AA		coil E3AE		coil F1AA			
50Hz	DC	50Hz	DC	50Hz	DC		
30,0	30,0	30,0	30,0	-	-	0,08	
30,0	30,0	30,0	30,0	-	-	0,08	
20,0	20,0	20,0	20,0	-	-	0,13	
20,0	20,0	20,0	20,0	-	-	0,13	
14,0	14,0	14,0	14,0	-	-	0,19	
14,0	14,0	14,0	14,0	-	-	0,19	
10,5	10,5	10,5	10,5	-	-	0,25	
10,5	10,5	10,5	10,5	-	-	0,25	
8,0	8,0	8,0	8,0	-	-	0,30	
8,0	8,0	8,0	8,0	-	-	0,30	
6,0	6,0	6,0	6,0	-	-	0,37	
6,0	6,0	6,0	6,0	-	-	0,37	
4,0	4,0	4,0	4,0	4,0	4,0	0,55	
4,0	4,0	4,0	4,0	4,0	4,0	0,55	
4,0	4,0	4,0	4,0	4,0	4,0	0,55	
4,0	4,0	4,0	4,0	4,0	4,0	0,67	
4,0	4,0	4,0	4,0	4,0	4,0	0,67	
4,0	4,0	4,0	4,0	4,0	4,0	0,67	

2/2-WAY SOLENOID VALVE

TYPE 20



O_2 oxygene applications

ORDER CODE

Type 20A, normally closed												
order code	20	A	-	2	E	30	-	A	E1AA	23050		
Type 20B, normally open												
order code	20	B	-	2	E	30	C	Z	-	A	E1AA	23050
Code decoding												
type	type 20, direct operated, body: brass, plunger tube: stainless steel											
function	A = normally closed, B = normally open											
ports	1 = G1/8, 2 = G1/4, 3 = G3/8, 4 = G1/2											
seal material	B = NBR (Perbunan), E = EPDM, V = FPM											
nominal size seat	15 = 1,5 mm, 20 = 2,0 mm, 25 = 2,5 mm, 30 = 3,0 mm, 35 = 3,5 mm, 40 = 4,0 mm, 50 = 5,0 mm, 60 = 6,0 mm, 80 = 8,0 mm, 100 = 10,0 mm											
throw off spring	C, D, F = only normally open											
stroke compensation spring	Z = only normally open											
short circuit ring	A = copper short circuit ring, X = without short circuit ring											
coil type	see specifications of the particular coil											
supply voltage	always 5-digits, see code for standard voltage											

DIMENSIONS

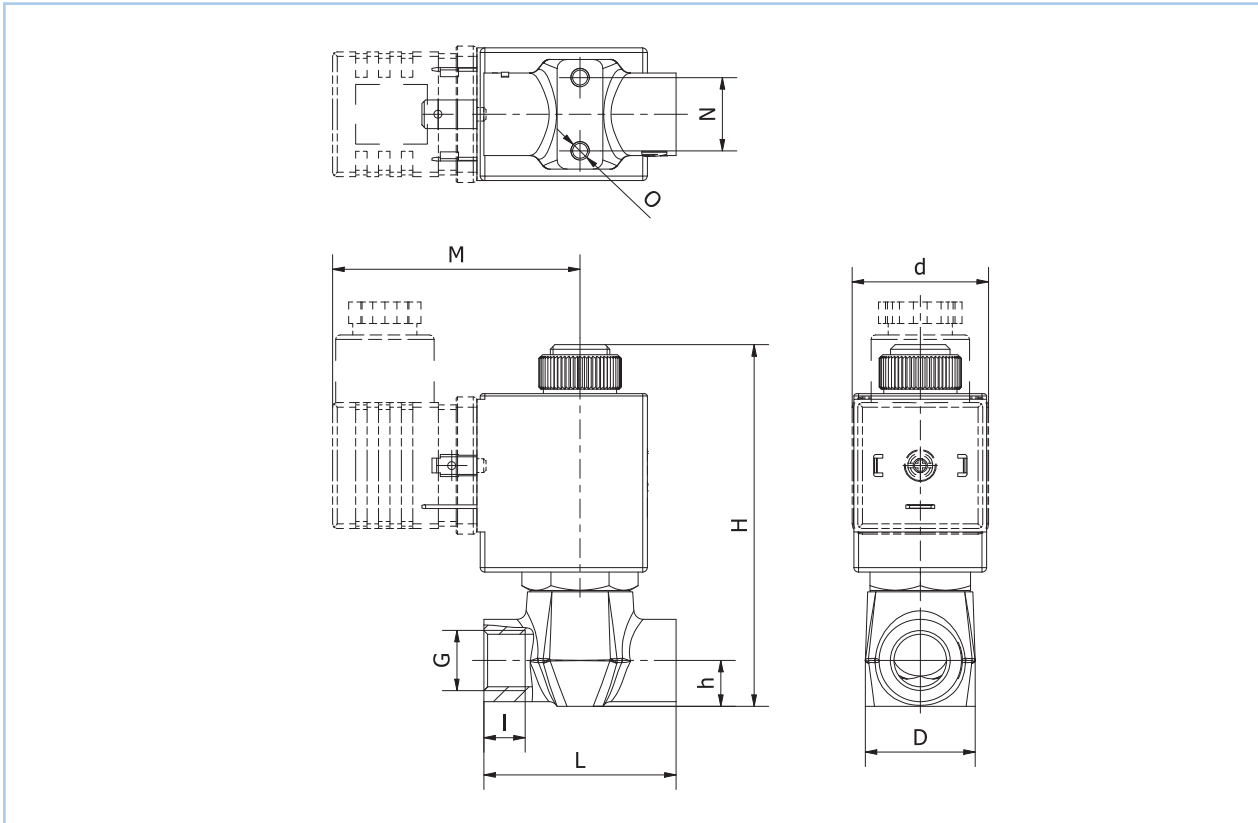

Dimension table for type 20 in mm, approx. weight in g

coil	G	N	O	M	H		d	h	I	L	D	approx. weight in g	
					type 20A	type 20B						type 20A	type 20B
E1	G1/8	16	M4	55,1	79	86	30	10	7,5	42	24	283	303
E2	G1/8	16	M4	57	79	86	35	10	7,5	42	24	349	369
E3	G1/8	16	M4	56	79	86	36	10	7,5	42	24	369	389
F1	G1/8	16	M4	57	90	96	38	10	7,5	42	24	439	429
E1	G1/4	16	M4	55,1	79	86	30	10	9	42	24	273	293
E2	G1/4	16	M4	57	79	86	35	10	9	42	24	339	359
E3	G1/4	16	M4	56	79	86	36	10	9	42	24	359	379
F1	G1/4	16	M4	57	90	96	38	10	9	42	24	429	419
E1	G3/8	16	M4	55,1	79	86	30	12	10	46	25/32*	380	400
E2	G3/8	16	M4	57	79	86	35	12	10	46	25/32*	446	466
E3	G3/8	16	M4	56	79	86	36	12	10	46	25/32*	466	486
F1	G3/8	16	M4	57	90	96	38	12	10	46	25/32*	536	526
E1	G1/2	16	M4	55,1	79	86	30	12	12	54	25/32*	390	410
E2	G1/2	16	M4	57	79	86	35	12	12	54	25/32*	456	476
E3	G1/2	16	M4	56	79	86	36	12	12	54	25/32*	476	496
F1	G1/2	16	M4	57	90	96	38	12	12	54	25/32*	546	536

*for nominal seat size 8 & 10 mm the body width D = 32 mm